

Alcoa  
Fastening  
Systems



## INSTRUCTION MANUAL

# MODELS 968 & 968D

## POWERIG<sup>®</sup> HYDRAULIC UNIT

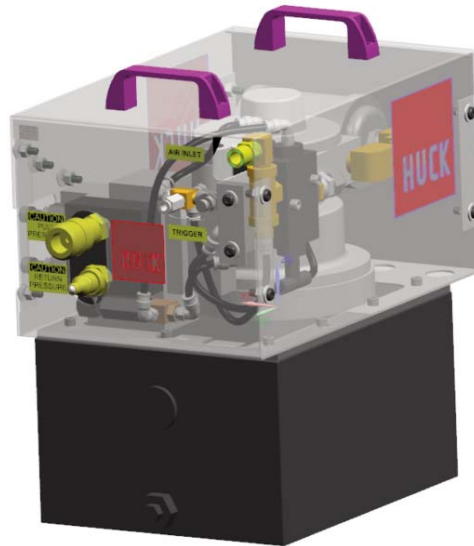

968

968D



Makers of Huck<sup>®</sup>, Marson<sup>®</sup>, Recoil<sup>®</sup>  
Brand Fasteners, Tools & Accessories

July 15, 2014  
HK1126





# EC Declaration of Conformity

**Manufacturer:**

Alcoa Fastening Systems, Industrial Products Group, 1 Corporate Drive, Kingston, NY, 12401, USA

**Description of Machinery:**

PA46 series (968 and 968D) Powerig®

**Relevant provisions complied with:**

EN, EN-ISO, ISO standards

Title

Per the provisions of the Machinery Safety Directive 2006/42 EC

EN_ISO 12100-1	Basic concepts, general principles for design - Part 1
EN_ISO12100-2	Basic concepts, general principles for design - Part 2
EN 982	Safety requirements for fluid power systems & their components - Hydraulics
EN 983:1996	Safety requirements for fluid power systems & their components - Pneumatics
EN ISO 13849-1:2008	Safety-related parts of control systems - Part 1
EN ISO 13849-2:2008	Safety-related parts of control systems - Part 2
EN ISO 14121-1:2007	Risk assessment - Part 1

**European Representative:**

Rob Pattenden, Huck International, Ltd. Unit C Stafford Park 7, Telford Shropshire TF3 3BQ, England, United Kingdom

**Authorized Signature/date:**

I, the undersigned, hereby declare that the equipment specified above conforms to the above European Communities Directive(s) and Standard(s).

Signature:

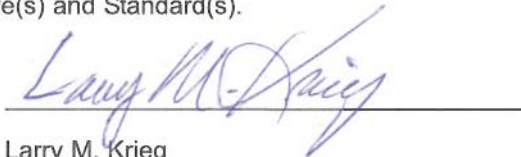

Full Name:

Larry M. Krieg

Position:

Engineering Manager  
Installation Systems Division

Place:

Kingston, New York, USA

Date:

June 2012

Test data to support the above information is on file at Alcoa Fastening Systems, Industrial Products Group, Kingston Operations, Kingston, NY, USA.



## CONTENTS

<b>SAFETY</b> .....	<b>4</b>
<b>PRINCIPLE OF OPERATION</b> .....	<b>5</b>
<b>DESCRIPTION</b> .....	<b>5</b>
<b>SPECIFICATIONS</b> .....	<b>6</b>
<b>OPTIONAL EQUIPMENT</b> .....	<b>6</b>
<b>ADDITIONAL SAFETY PRECAUTIONS</b> .....	<b>7</b>
<b>OPERATING INSTRUCTIONS</b> .....	<b>7</b>
<b>TOOL TO POWERIG SETUP</b> .....	<b>8</b>
<b>MAINTENANCE</b> .....	<b>9</b>
<b>PARTS DRAWINGS</b> .....	<b>10-11</b>
<b>TROUBLESHOOTING</b> .....	<b>12</b>



## SAFETY INSTRUCTIONS

### GLOSSARY OF TERMS AND SYMBOLS:



- Product complies with requirements set forth by the relevant European directives.



- **READ MANUAL** prior to using this equipment.



- **EYE PROTECTION IS REQUIRED** while using this equipment.



- **HEARING PROTECTION IS REQUIRED** while using this equipment.



**WARNINGS: Must be understood to avoid severe personal injury.**



**CAUTIONS: show conditions that will damage equipment and or structure.**

**Notes:** are reminders of required procedures.

***Bold, Italic type and underlining:*** emphasizes a specific instruction.

1. A half hour long hands-on training session with qualified personnel is recommended before using Huck equipment.
2. Huck equipment must be maintained in a safe working condition at all times. Tools and hoses should be inspected at the beginning of each shift/day for damage or wear. Any repair should be done by a qualified repairman trained on Huck procedures.
3. Repairman and Operator must read manual prior to using equipment. Warning and Caution stickers/labels supplied with equipment must be understood before connecting equipment to any primary power supply. As applicable, each of the sections in this manual have specific safety and other information.
4. Read MSDS Specifications before servicing the tool. MSDS Specifications are available from the product manufacturer or your Huck representative.
5. When repairing or operating Huck installation equipment, always wear approved eye protection. Where applicable, refer to ANSI Z87.1 - 2003
6. Only genuine Huck parts shall be used for replacements or spares. Use of any other parts can result in tooling damage or personal injury.
7. If a part affixed with warning labels is replaced, or labels are missing or damaged, the end user is responsible for replacement. Refer to assembly drawing and parts list for replacement part number and proper placement.
8. Disconnect primary power source before performing maintenance on Huck equipment or changing Nose Assembly.
9. Tools and hoses should be inspected for leaks at the beginning of each shift/day. If any equipment shows signs of damage, wear, or leakage, do not connect it to the primary power supply.
10. Mounting hardware should be checked at the beginning of each shift/day.
11. Make sure proper power source is used at all times.
12. Release tool trigger if power supply is interrupted.
13. Tools are not to be used in an explosive environment unless specifically designed to do so.
14. Never remove any safety guards or pintail deflectors.
15. Where applicable, ensure deflector or pintail collector is installed and operating prior to use.
16. Never install a fastener in free air. Personal injury from fastener ejecting may occur.
17. Where applicable, always clear spent pintail out of nose assembly before installing the next fastener.
18. There is possibility of forcible ejection of pintails or spent mandrels from front of tool.
19. Check clearance between trigger and work piece to ensure there is no pinch point when tool is activated. Remote triggers are available for hydraulic tooling if pinch point is unavoidable.
20. Unsuitable postures may not allow counteracting of normal expected movement of tool.
21. Do not abuse tool by dropping or using it as a hammer. Never use hydraulic or air lines as a handle or to bend or pry the tool. Reasonable care of installation tools by operators is an important factor in maintaining tool efficiency, eliminating downtime, and in preventing an accident which may cause severe personal injury.
22. Never place hands between nose assembly and work piece. Keep hands clear from front of tool.
23. There is a risk of crushing if tool is cycled without Nose Assembly installed.
24. Tools with ejector rods should never be cycled with out nose assembly installed.
25. When two piece lock bolts are being used always make sure the collar orientation is correct. See fastener data sheet for correct positioning.
26. Tool is only to be used as stated in this manual. Any other use is prohibited.
27. There is a risk of whipping compressed air hose if tool is pneumatic or hydraulic.
28. Release the trigger in case of failure of air supply or hydraulic supply.
29. Use only fluids or lubricants recommended.
30. Disposal instruction: Disassemble and recycle steel, aluminum and plastic parts, and drain and dispose of hydraulic fluid in accordance with local lawful and safe practices.
31. If tool is fixed to a suspension device, ensure that the device is secure prior to operating the tool.



## PRINCIPLE OF OPERATION

When tool trigger is depressed, the directional valve changes positions so that high-pressure hydraulic fluid is directed out the PULL pressure port and hose to tool 1.

When the tool trigger is released, the valve spool returns to its original position, directing the hydraulic fluid out the RETURN pressure port and hose to the tool.

## DESCRIPTION

The Huck Model 968 POWERIG® is a portable, air powered hydraulic power source designed to operate Huck Hydraulic Installation Equipment.

Hydraulic pressure is developed by two hydraulic piston pumps driven by air motors. Pump output is directed to either PULL or RETURN pressure ports of the installation tool by air operated directional valve. The hydraulic unit is controlled, with air trigger, from the tool.

Internal relief valves are pre-set at the factory for the protection of operator and equipment. External relief valves control PULL Pressure and RETURN Pressure. As shipped from the factory,

external relief valve is set at 5400-5700 psi (37200-39300 kPa) and return pressure valve is set at 2700-3300 psi (15200-16500 kPa). Pressures are adjustable to match Huck installation tool being used. See applicable installation tool manual.

Hydraulic fluid is stored in a reservoir. Hydraulic quick disconnect couplers are furnished for connecting installation tool.

The unit weighs approximately **75 pounds (34 kg)** without the optional dolly assembly, and when filled with hydraulic fluid.

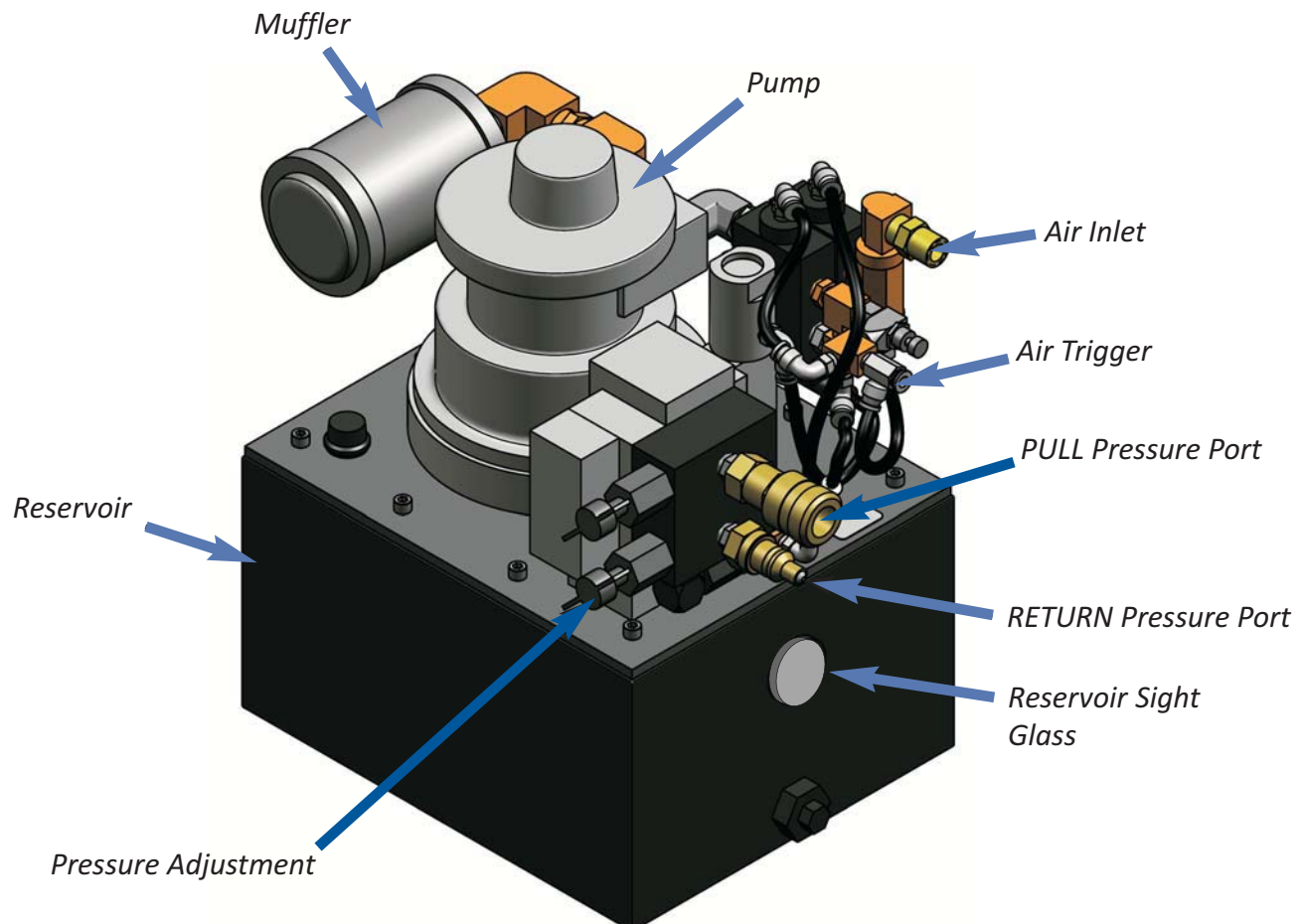



## SPECIFICATIONS

<b><u>Width</u></b>	16.33 (41.5 cm)
<b><u>Length</u></b>	10.45 (26.5 cm)
<b><u>Height</u></b>	15.68 (39.83 cm)
<b><u>Weight</u></b>	75 lbs. (34 kg)
<b><u>Operational Weight</u></b>	93 lbs. (42 kg)
<b><u>Power Source</u></b>	Air supply must be minimum 50 CFM (.024 m <sup>3</sup> /s)
<b><u>Hose Kits</u></b>	Use only genuine HUCK Hose Kits rated @ 10,000 psi working pressure.
<b><u>Reservoir Capacity</u></b>	2.5 gallons (9.5 liters)
<b><u>Output Pressure</u></b>	
<b>PULL (max):</b>	8800 psi (606 bar)
<b>RETURN (max):</b>	3500 psi (241 bar)
<b><u>Max Operating Temp</u></b>	125 ° F ( 51.7 ° C)
<b><u>Max Flow Rate</u></b>	1.95 gpm per circuit ( 7.37 l/m)

**Hydraulic Fluid** ATF meeting DEXRON III, DEXRON IV, MERCON, Allison C-4 or equivalent specifications.

Fire resistant hydraulic fluid may also be used, and is required to comply with OSHA regulation 1926.302 paragraph (d): "the fluid used in hydraulic power tools shall be fire resistant fluid approved under schedule 30 of the US Bureau of Mines, Department of Interior, and shall retain its operating characteristics at the most extreme temperatures to which it will be exposed."

**Declared dual number noise emission values in accordance with ISO 4871:**

A weighted sound power level, LWA: 107 dB (reference 1 pW) Uncertainty, KWA: 3 dB

A weighted emission sound pressure level at the work station, LpA: 96 dB (reference 20 µPa) Uncertainty, KpA: 3 dB

C-weighted peak emission sound pressure level, LpC: 108 dB (reference 20 µPa) Uncertainty, KpC: 3 dB  
Values determined according to noise test code ISO 15744, using as basic standards ISO 3744 and ISO 11203.

## OPTIONAL EQUIPMENT

Shown here is the 968D.  
This is the 968 Powerig with the optional Dolly Assembly, Huck part number 129703 which offers convenient portability.



**Note:** Prior to use, make sure casters are locked.







## ADDITIONAL SAFETY PRECAUTIONS

### HYDRAULIC HOSES

1. Before operating the pump, all hose connections must be tightened using the proper tools. Do NOT overtighten. Connections need only be secure and leak-free. Overtightening may cause premature thread failure or may cause high pressure fittings to split at pressures lower than their rated capacities.
2. If a hydraulic hose ever ruptures, bursts, or needs to be disconnected, immediately shut off the pump. Never attempt to grasp a leaking hose under pressure with your hands. The force of escaping hydraulic fluid could cause serious injury.

3. Do not use the hose to move attached equipment. Stress may damage the hose and possibly cause personal injury.

### AIR MOTOR

1. Disconnect the air supply when the pump is not in use or when breaking any connection in the hydraulic system.
2. It is recommended that a shut-off valve or quick disconnect be installed in the air line to the pump unit. Close the shut-off valve before connecting the air line to the pump.

## OPERATING INSTRUCTIONS

### FIRST TIME USE

1. Remove shipping plug from top of Reservoir and replace with Filler Breather Cap. (Fig. 1) Be sure O-ring is in place on Filler Breather Cap before installing.
2. Fill reservoir with hydraulic fluid, approximately 2 quarts (1.9 liters), until the fluid level is within one inch of the top of the reservoir.
3. Use a T-gauge, Huck part no. T-124833CE, to set Pull and Return pressures to the appropriate values for the installation tool.
4. Attach installation tool to Powerig. Be sure that hose from PULL PRESSURE on the unit runs to port "P" of the tool and hose from RETURN PRESSURE on the unit runs to port "R" of the tool.
5. Connect air supply.
6. Depress tool switch and let unit operate for a few minutes to circulate hydraulic fluid and remove air from the system.
7. Check fluid level in reservoir and add hydraulic fluid as required.
8. The unit and installation tool are now ready for attaching the applicable nose assembly and the installation of Huck fasteners.

### AIR SUPPLY HOOK-UP

Minimum air supply must be 50 CFM (.57 M<sup>3</sup>/min.) and 80 PSI (6-7 BAR), with 100 PSI (XX BAR) being the maximum.

1. Secure pump fitting to the air supply.
2. Assemble the hoses. Clean the areas around the oil ports of the valve and hydraulic cylinders, and remove the plastic thread protectors. Clean all hose ends, couplers, or union ends. Inspect all threads and fittings for signs of wear or damage and replace as needed.
3. FILL the RESERVOIR: Remove the filler cap and insert a clean funnel. Fill the reservoir with hydraulic oil to top of sight glass. Replace the filler cap with the breather hole open.

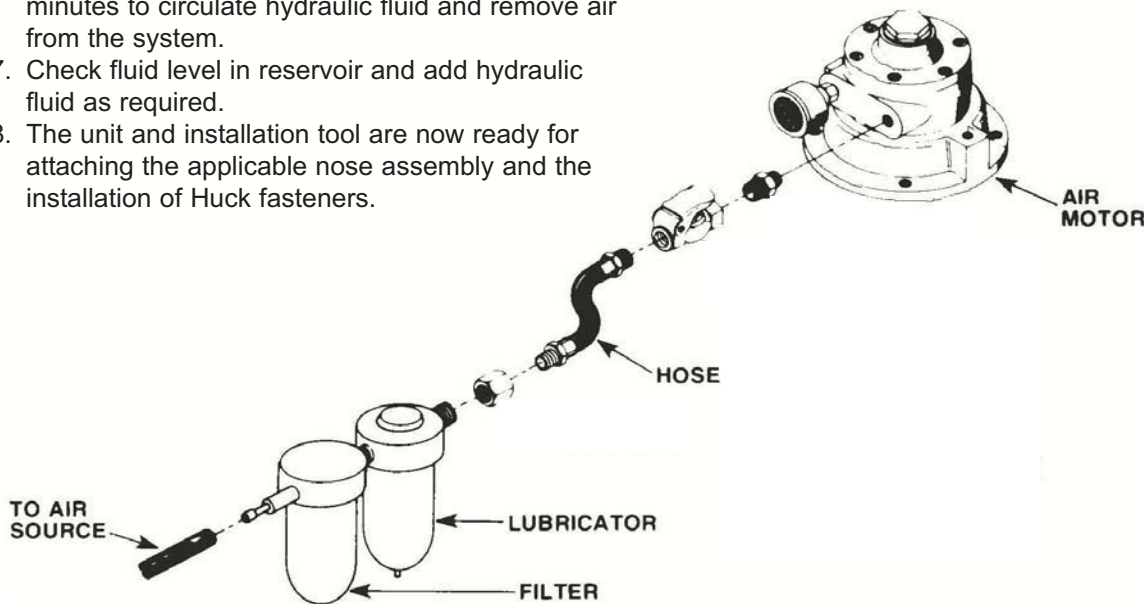



## TOOL TO POWERIG SETUP



### WARNINGS:

Read full manual before using tool.

A half-hour training session with qualified personnel is recommended before using Huck equipment.

When operating Huck installation equipment, always wear approved eye protection.

Be sure there is adequate clearance for the operator's hands before proceeding.



**WARNING:** Correct PULL and RETURN pressures are required for operator's safety and for Installation Tool's function. Gage part number T-124833CE is available for checking pressures. See Tool SPECIFICATIONS and Gauge Instruction Manual. Failure to verify pressures may result in severe personal injury.



**WARNING:** Be sure to connect Tool's hydraulic hoses to POWERIG Hydraulic Unit before connecting Tool's switch control cord to unit. If not connected in this order, severe personal injury may occur.



**WARNING:** To prevent tripping hazard, suspend tools and route hoses off of floors.



**WARNING:** Only use compatible equipment with this Powerig.

**NOTE:** To decrease Relief Valve pressure, turn the Relief Valve handle gradually counterclockwise; turn clockwise to increase pressure.

1. With the Nose Assembly in place on the Installation Tool, begin setup. First connect the Hydraulic Hoses to the Powerig.
2. Set Pull and Return pressures on Powerig using Huck Gage P/N: T-124833CE according to pressure settings recommended with tool to be used.
3. Once the system is set up, install test fastener. Check to be sure that the fastener is installed correctly. This can be checked by inspecting the dimples on the collar flange. At least one dimple should be marked by the anvil.





## MAINTENANCE

### GOOD PRACTICES

The introduction of foreign material into the hydraulic system will result in poor performance and repair downtime. To avoid this, observe the following good practices:

1. When filling reservoir with hydraulic fluid, clean area around filler cap before removing. Always filter hydraulic fluid using a 10-15 micron filter before adding to powerig.
2. Use clean funnel with filter.
3. Do not let hose fittings or couplings lie, or drag on floor.
4. Wipe off couplings before connecting them.
5. Periodically, drain and clean reservoir and fill with clean fluid.

### REGULAR USE

Before using Hydraulic Unit:

1. Check hydraulic fluid level in reservoir and add fluid as required.
2. Inspect hoses for damage and replace as required.
3. Check entire system for leaks and repair as needed

## PREVENTIVE MAINTENANCE

### LUBRICATION OF THE AIR-DRIVEN MOTOR

If the pump is operated on a continuous duty cycle or at maximum speed for an extended period, an automatic air line oiler is recommended. Install the oiler in the air inlet line as close to the pumping unit as possible. Adjust the oiler to feed 1-3 drops of SAE #10 oil per minute (one drop for every 50-75 CFM of air) into the system.

### HYDRAULIC FLUID LEVEL

Check the oil level in the reservoir after each 10 hours of use. Proper oil level is to top of sight glass.

### ADDING OIL TO THE RESERVOIR

Use only recommended hydraulic fluid. Disconnect power supply when adding oil to the reservoir. Clean the entire area around the filler plug before removing the filler plug. Use a clean funnel with filter when adding oil.

### MAINTENANCE CLEANING

Keep the outer surface of the pump, all hose connections and any equipment hooked up to the pump as free of dirt and oil as possible. The breather hole in the filler cap must be kept clean and unobstructed at all times. All unused couplers are to be sealed with thread protectors. Change oil as recommended.



# PARTS DRAWINGS

Item	Description	Part No.	Qty.
1	Cover Plate Assy	130140	1
2	Reservoir Gasket	130141	1
3	Motor Base Gasket	130142	2
4	Air Motor	130143	1
5	Motor Shaft Coupling	130145	1
6	Drain	130146	1
7	Plug Fitting	508485	1
8	Nut	506457	1
9	O-Ring	508486	1
10	Muffler	508487	1
11	Sight Gauge	508488	1
12	Air Valve	130148	1
13	Air Valve, 3-way	130149	1
14	Elbow Tube Fitting	508483	9
15	Straight Fitting	508484	1
16	Straight Fitting	508489	1
17	Breather Fitting	508490	1
18	Tee Fitting	508491	3
19	Flow Control Valve	130150	1
20	Tee Fitting	508492	1
21	Rear Cover Base	129504	1

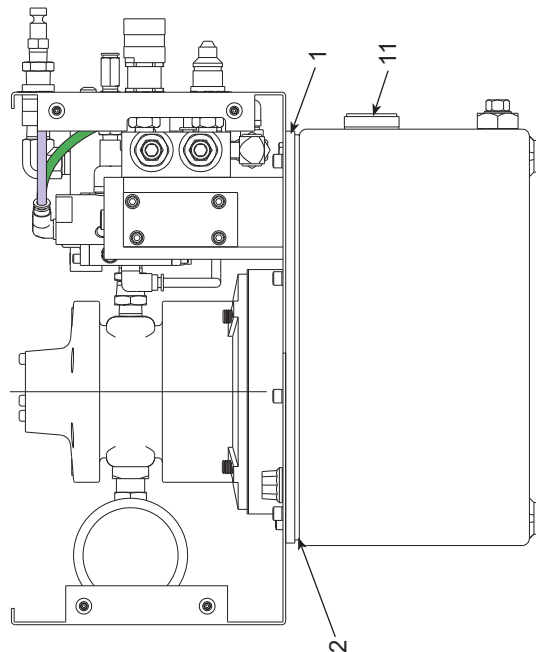
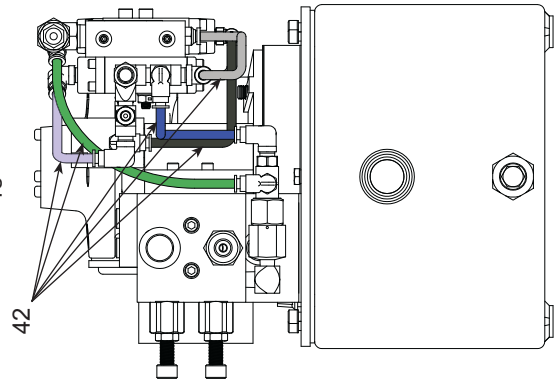
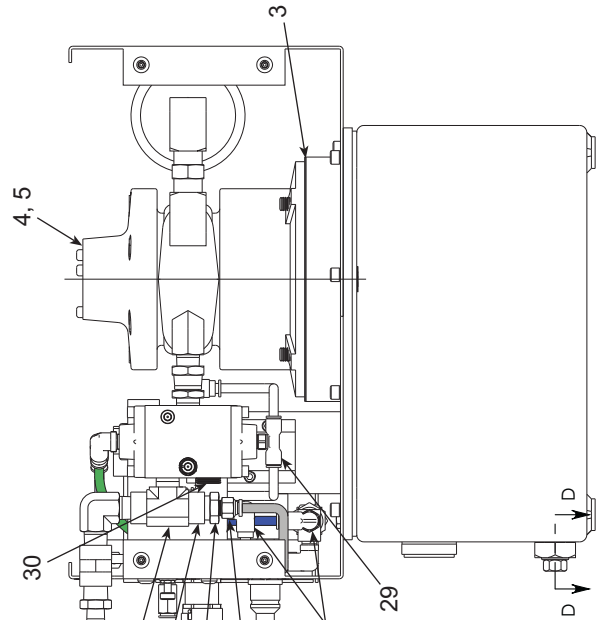
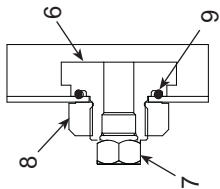
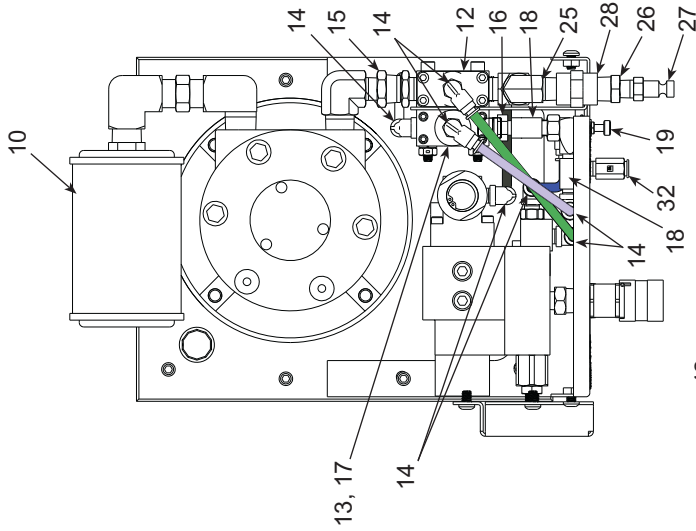



**PARTS DRAWINGS** *continued*

Item	Description	Part No.	Qty.
22	Front Cover Base	129505	1
23	Top Cover	129506	1
24	Valve Support Bracket	129508	2
25	Elbow Fitting	508493	1
26	Straight Fitting	508494	1
27	Male Fitting	508495	1
28	Straight Fitting	508496	1
29	Tee Fitting	508497	1
30	Plug Fitting	508498	1
31	Straight Fitting	508499	1
32	Quick Coupler	508500	1
33	Pull Handle	130147	1
34	Relief Valve Cover	129690	1
35	Product Decal	590532	9
36	Trigger Decal	590520	1
37	Air Inlet Decal	590519	1
38	Caution Pull Decal	590533	1
39	Caution Return Decal	590534	3
40	CE Decal	590535	1
41	Huck Address Decal	590347	1
42	Tubing, Black	508501	1

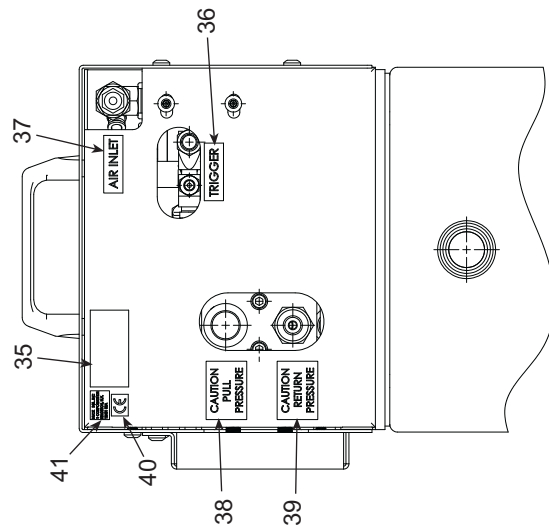
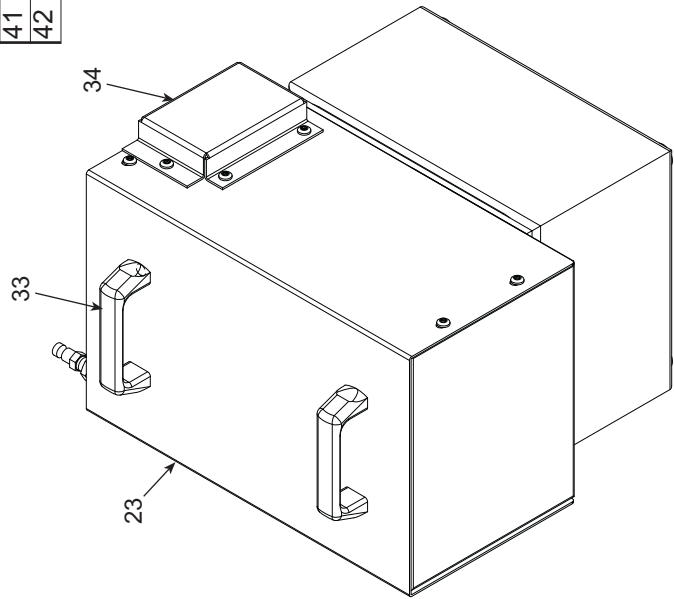
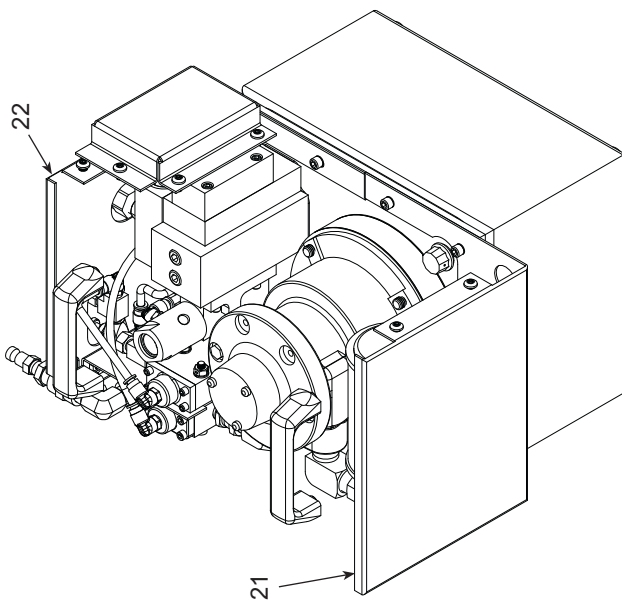



## **TROUBLESHOOTING**

NOTE: Use the proper gauges and equipment when troubleshooting. Depending on the pump version, it is often best to check for leaks by using a hand pump and applying pressure to the suspect area without the motor running. Watch for leaking oil and follow it back to its source. Plug the outlet ports of the pump when checking for leakage to determine if the leakage is in the pump or if it is in the cylinder or tool.

- 1. Tool fails to operate when trigger is depressed.**
  - a. Loose or faulty air connectors on control hose.
  - b. Loose or faulty hydraulic hose couplings.
  - c. Defective tool air trigger assembly.
  - d. Air trigger sensitivity needs adjusting.
  - e. Low hydraulic fluid level in reservoir.
  - f. Hydraulic fluid viscosity too heavy to pick up prime.
  - g. Clogged suction screen.
  - h. Defective hydraulic pump.
  - i. Defective spool valve assembly.
  - j. Installation tool defective
  
- 2. Tool does not return on release of trigger.**
  - a. Defective spool valve.
  - b. Installation tool not operating properly.
  - c. Air trigger sensitivity needs adjusting.
  - d. Hoses not coupled properly.
  - e. Return pressure set to low.
  
- 3. Pump runs but will not build pressure.**
  - a. Low hydraulic fluid level in reservoir.
  - b. Clogged suction screen.
  - c. Hydraulic fluid viscosity too heavy to pick up prime.
  - d. Pump check valve is leaking.
  - e. Defective air motor.
  - f. Pull pressure set too low
  
- 4. Tool operation slow but entire cycle does occur.**
  - a. Pump check valve is leaking.
  - b. Hydraulic fluid viscosity too thin.
  - c. Defective spool valve assembly.
  - d. Clogged suction screen.
  - e. Defective air motor.
  - f. Internal or external relief valve not operating properly.



## **LIMITED WARRANTIES**

### **TOOLING WARRANTY:**

Huck warrants that tooling and other items (excluding fasteners, and hereinafter referred as "other items") manufactured by Huck shall be free from defects in workmanship and materials for a period of ninety (90) days from the date of original purchase.

### **WARRANTY ON "NON STANDARD OR CUSTOM MANUFACTURED PRODUCTS":**

With regard to non-standard products or custom manufactured products to customer's specifications, Huck warrants for a period of ninety (90) days from the date of purchase that such products shall meet Buyer's specifications, be free of defects in workmanship and materials. Such warranty shall not be effective with respect to non-standard or custom products manufactured using buyer-supplied molds, material, tooling and fixtures that are not in good condition or repair and suitable for their intended purpose.

**THERE ARE NO WARRANTIES WHICH EXTEND BEYOND THE DESCRIPTION ON THE FACE HEREOF. HUCK MAKES NO OTHER WARRANTIES AND EXPRESSLY DISCLAIMS ANY OTHER WARRANTIES, INCLUDING IMPLIED WARRANTIES AS TO MERCHANTABILITY OR AS TO THE FITNESS OF THE TOOLING, OTHER ITEMS, NONSTANDARD OR CUSTOM MANUFACTURED PRODUCTS FOR ANY PARTICULAR PURPOSE AND HUCK SHALL NOT BE LIABLE FOR ANY LOSS OR DAMAGE, DIRECTLY OR INDIRECTLY, ARISING FROM THE USE OF SUCH TOOLING, OTHER ITEMS, NONSTANDARD OR CUSTOM MANUFACTURED PRODUCTS OR BREACH OF WARRANTY OR FOR ANY CLAIM FOR INCIDENTAL OR CONSEQUENTIAL DAMAGES.**

Huck's sole liability and Buyer's exclusive remedy for any breach of warranty shall be limited, at Huck's option, to replacement or repair, at FOB Huck's plant, of Huck manufactured tooling, other items, nonstandard or custom products found to be defective in specifications, workmanship and materials not otherwise the direct or indirect cause of Buyer supplied molds, material, tooling or fixtures. Buyer shall give Huck written notice of claims for defects within the ninety (90) day warranty period for tooling, other items, nonstandard or custom products described above and Huck shall inspect products for which such claim is made.

### **TOOLING, PART(S) AND OTHER ITEMS NOT MANUFACTURED BY HUCK:**

**HUCK MAKES NO WARRANTY WITH RESPECT TO THE TOOLING, PART(S) OR OTHER ITEMS**

**MANUFACTURED BY THIRD PARTIES. HUCK EXPRESSLY DISCLAIMS ANY WARRANTY EXPRESSED OR IMPLIED, AS TO THE CONDITION, DESIGN, OPERATION, MERCHANTABILITY OR FITNESS FOR USE OF ANY TOOL, PART(S), OR OTHER ITEMS THEREOF NOT MANUFACTURED BY HUCK. HUCK SHALL NOT BE LIABLE FOR ANY LOSS OR DAMAGE, DIRECTLY OR INDIRECTLY, ARISING FROM THE USE OF SUCH TOOLING, PART(S) OR OTHER ITEMS OR BREACH OF WARRANTY OR FOR ANY CLAIM FOR INCIDENTAL OR CONSEQUENTIAL DAMAGES.**

The only warranties made with respect to such tool, part(s) or other items thereof are those made by the manufacturer thereof and Huck agrees to cooperate with Buyer in enforcing such warranties when such action is necessary.

Huck shall not be liable for any loss or damage resulting from delays or nonfulfillment of orders owing to strikes, fires, accidents, transportation companies or for any reason or reasons beyond the control of the Huck or its suppliers.

### **HUCK INSTALLATION EQUIPMENT:**

Huck International, Inc. reserves the right to make changes in specifications and design and to discontinue models without notice.

Huck Installation Equipment should be serviced by trained service technicians only.

Always give the Serial Number of the equipment when corresponding or ordering service parts.

Complete repair facilities are maintained by Huck International, Inc. Please contact one of the offices listed below.

#### Eastern

One Corporate Drive Kingston, New York 12401-0250  
Telephone (845) 331-7300 FAX (845) 334-7333

#### Outside USA and Canada

Contact your nearest Huck International Office, see back cover.

In addition to the above repair facilities, there are Authorized Tool Service Centers (ATSC's) located throughout the United States. These service centers offer repair services, spare parts, Service Parts Kits, Service Tools Kits and Nose Assemblies. Please contact your Huck Representative or the nearest Huck office listed on the back cover for the ATSC in your area.



For the Long Haul™

## A Global Organization

Alcoa Fastening Systems (AFS) maintains company offices throughout the United States and Canada, with subsidiary offices in many other countries. Authorized AFS distributors are also located in many of the world's

Industrial and Aerospace centers, where they provide a ready source of AFS fasteners, installation tools, tool parts, and application assistance.

## Alcoa Fastening Systems world-wide locations:

### Americas

**Alcoa Fastening Systems**  
Aerospace Products  
Tucson Operations  
3724 East Columbia  
Tucson, AZ 85714  
800-234-4825  
520-747-9898  
FAX: 520-748-2142

**Alcoa Fastening Systems**  
Aerospace Products  
Carson Operations  
PO Box 5268  
900 Watson Center Rd.  
Carson, CA 90749  
800-421-1459  
310-830-8200  
FAX: 310-830-1436

**Alcoa Fastening Systems**  
Industrial Products  
Waco Operations  
PO Box 8117  
8001 Imperial Drive  
Waco, TX 76714-8117  
800-388-4825  
254-776-2000  
FAX: 254-751-5259

**Alcoa Fastening Systems**  
Industrial Products  
Kingston Operations  
1 Corporate Drive  
Kingston, NY 12401  
800-278-4825  
845-331-7300  
FAX: 845-334-7333

**Alcoa Fastening Systems**  
Industrial Products  
Latin America Operations  
Avenida Parque Lira. 79-402  
Tacubaya Mexico, D.F.  
C.P. 11850  
FAX: 525-515-1776  
TELEX: 1173530 LUKSME

### Far East

**Alcoa Fastening Systems**  
Industrial Products  
Australia Operations  
14 Viewtech Place  
Rowville, Victoria  
Australia 3178  
03-764-5500  
Toll Free: 008-335-030  
FAX: 03-764-5510

### Europe

**Alcoa Fastening Systems**  
Industrial Products  
United Kingdom Operations  
Unit C, Stafford Park 7  
Telford, Shropshire  
England TF3 3BQ  
01952-290011  
FAX: 0952-290459

**Alcoa Fastening Systems**  
Aerospace Products  
France Operations  
Clos D'Asseville  
BP4  
95450 Us Par Vigny  
France  
33-1-30-27-9500  
FAX: 33-1-34-66-0600



*For The Long Haul, The Future of Fastening Technology, The Future of Assembly Technology, The Future of Tooling Technology, and Tools of Productivity are service marks of Huck International. Huck provides technical assistance regarding the use and application of Huck fasteners and tooling.*

*NOTICE: The information contained in this publication is only for general guidance with regard to properties of the products shown and/or the*

*means for selecting such products, and is not intended to create any warranty, express, implied, or statutory; all warranties are contained only in Huck's written quotations, acknowledgements, and/or purchase orders. It is recommended that the user secure specific, up-to-date data and information regarding each application and/or use of such products.*

**HWB898 1003-5M**

# Alcoa Fastening Systems



One Great Connection<sup>SM</sup>